

The Sensible Heat Lossnay LGH-RVS Series, allows diverse solutions and options in response to customer needs.

Three key features, namely “Easy Installation”, “Low Noise Operation”, and “High Energy Efficiency”, provide energy savings and comfort!

CO₂ Sensor

A CO₂ sensor connected directly to a Lossnay RVS unit optimizes the fan speed according to the level of CO₂ detected. It improves total heat exchange efficiency and contributes to energy saving.

PZ-70CSW-E (Wall mounted type)

CO₂ levels are indicated by LED lights.



PZ-70CSB-E (Built-in type)



■ Automatic operation with CO₂ sensor and PZ-62DR-E
Fan speed automatically changes depending on CO₂ concentration.

Accessories

Filters

A lineup of three types of filters offers optimum indoor air quality solutions! All filters are ISO and EN779:2012 certified, and can be easily installed in the units. Maintenance and exchanges can also be performed easily, simply by opening the maintenance panel.



Standard Filter

Filter material	Filter			Included piece/set	Lossnay	
	Classification		Model name		Applicable model	Required set/unit
	ISO 16890 (2016)	EN779 (2012)				
Non-woven fabrics	Coarse 50%	G3	PZ-S50RF-E	2	LGH-50RVS-E	1
			PZ-S80RF-E	2	LGH-80RVS-E	1
			PZ-S100RF-E	2	LGH-100RVS-E	1

Medium-efficiency Filter

Filter material	Filter			Included piece/set	Lossnay	
	Classification		Model name		Applicable model	Required set/unit
	ISO 16890 (2016)	EN779 (2012)				
Pleated filter	ePM ₁₀ 80%	M6	PZ-S50RFM-E	2	LGH-50RVS-E	1
			PZ-S80RFM-E	2	LGH-80RVS-E	1
			PZ-S100RFM-E	2	LGH-100RVS-E	1

High-efficiency Filter

Filter material	Filter			Included piece/set	Lossnay	
	Classification		Model name		Applicable model	Required set/unit
	ISO 16890 (2016)	EN779 (2012)				
Pleated filter	ePM ₁₀ 90%	F8	PZ-S50RFH-E	2	LGH-50RVS-E	1
			PZ-S80RFH-E	2	LGH-80RVS-E	1
			PZ-S100RFH-E	2	LGH-100RVS-E	1

Silencer Ducts

In facilities and applications requiring quiet operations, the silencer duct that reduces noise levels is the ideal solution. It contains glass wool and attenuates sound power by absorbing the noise from the airflow or operation of the unit.



Model	Direction	Air flow	Attenuation of sound power level [dB] for center frequency							
			62.5Hz	125Hz	250Hz	500Hz	1000Hz	2000Hz	4000Hz	8000Hz
PZ-200SS-E	Discharge	500 m ³ /h	0	1	4	7	13	18	16	9
		650 m ³ /h	0	1	3	8	12	17	14	6
	Suction	500 m ³ /h	0	1	4	8	11	17	14	8
		650 m ³ /h	0	0	3	7	10	11	12	5
PZ-250SS-E	Discharge	800 m ³ /h	0	2	4	12	22	21	14	13
		1000 m ³ /h	0	1	4	12	22	20	14	13
	Suction	800 m ³ /h	0	3	5	12	18	14	11	4
		1000 m ³ /h	0	2	4	12	17	16	13	8

- Figures on the chart above are based on the comparison with a general steel duct of the same length.
- The silencer is placed on just before the outlet during the measurement.
- When the air flow rate differs, the insertion loss is also different from the chart above.
- Figures on the chart above are flat (No-weighted) values.

MITSUBISHI ELECTRIC CORPORATION

www.MitsubishiElectric.com

LGH-RVS Series

LGH-100RVS-E

LGH-80RVS-E

LGH-50RVS-E

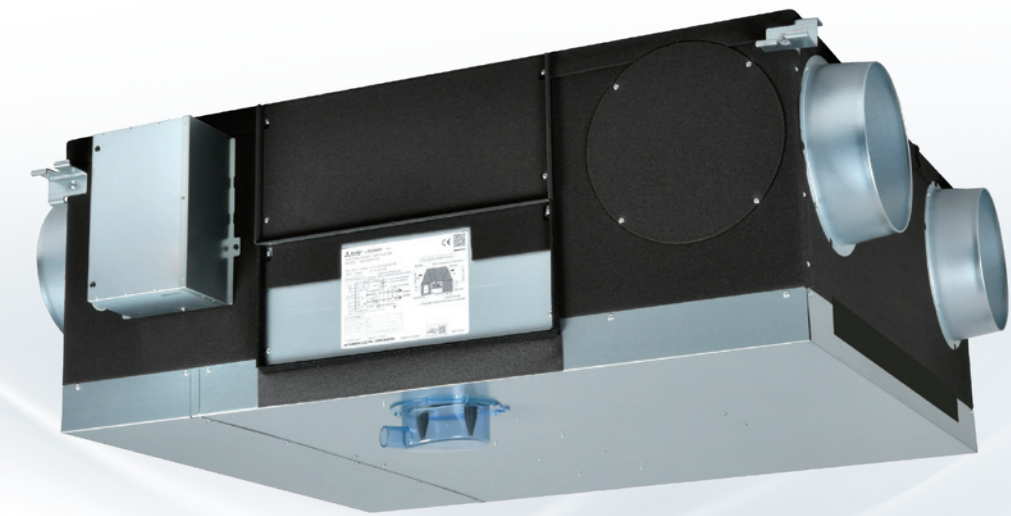

**Offering the Best System Solution
for All Area Ventilation**

Key Features

Easy Installation

Light Chassis

Being light in weight is one of the most important factors for installation. The light chassis of the LGH-RVS series can provide a huge advantage in terms of cost and safety in installation.

Easy Drain Piping

- Only one drain piping for both SA and EA.
- 360-degree drain pipe connection.
- Trap piping work is NOT required owing to an internal backflow stopper.

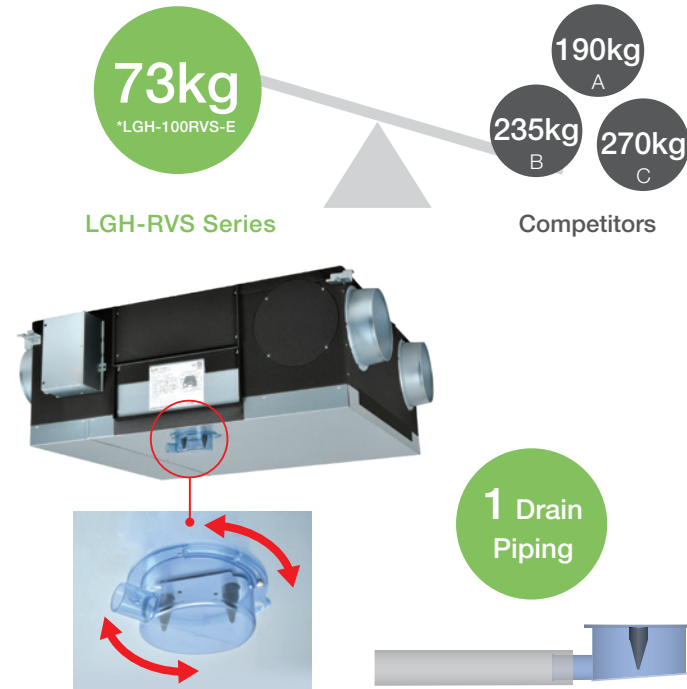

Low Noise Operation and Energy Efficiency

The LGH-RVS series operates with low noise thanks to a specialized sirocco fan produced by Mitsubishi Electric. The fan balances airflow and static pressure to minimize the noise level. The series also incorporates high-efficiency motor to reduce energy consumption. Low noise and high efficiency are thus achieved with the LGH-RVS series!



Various Optional Parts

The LGH-RVS series can connect with various optional parts. A CO₂ sensor is one of the best solutions for optimized air volume control. The unit operates while optimizing air volume in accordance with the level of CO₂ condensation in the room. Optimized ventilation can reduce the energy consumption of the air conditioner. A high-efficiency filter can be optionally installed in the unit as an easy solution for even better indoor air quality.

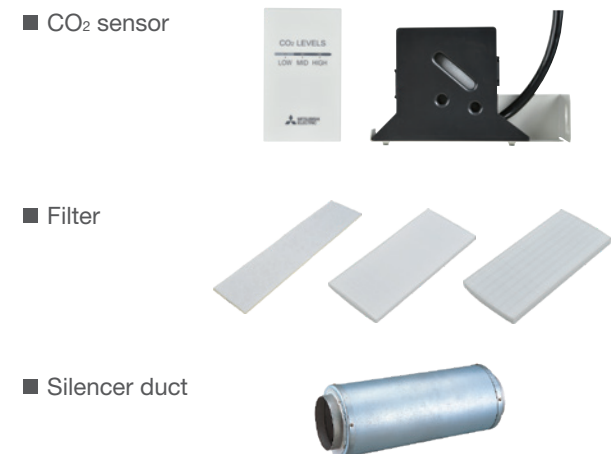

Specifications

LGH-100RVS-E	73kg (89kg with maximum drain water)				
	220-240V/50Hz, 220V/60Hz				
Electrical power supply	Test condition				
Fan speed	100%	75%	50%	25%	
Input power [W]	445	225	100	35	
Airflow [m ³ /h]	1000	750	500	250	
Airflow [L/s]	278	208	139	69	ISO 16494
Specific fan power [W/(L/s)]	1.60	1.08	0.72	0.50	Temp. exchange efficiency is winter condition
External static pressure [Pa]	190	107	48	12	
Temp. exchange efficiency [%]	82.0	84.0	86.0	90.0	A-weighted sound pressure level @1.5m off from the center of the unit in an anechoic chamber
Noise [dB]	37.0	32.0	24.0	18.0	Tracer gas method @100% airflow (prEN308)
Exhaust air transfer ratio [%]	5				
Insulation resistance	10MΩ or more				
Dielectric strength	AC 1000V 1 minute				
Maximum current [A]	4.20				
Inrush current [A]	6.1A @10ms, 3.6A@100ms				

Characteristic Curves

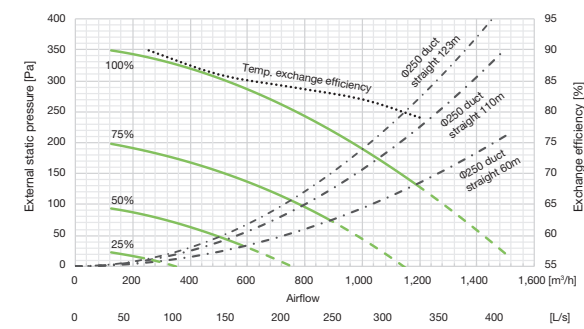

Dimensions

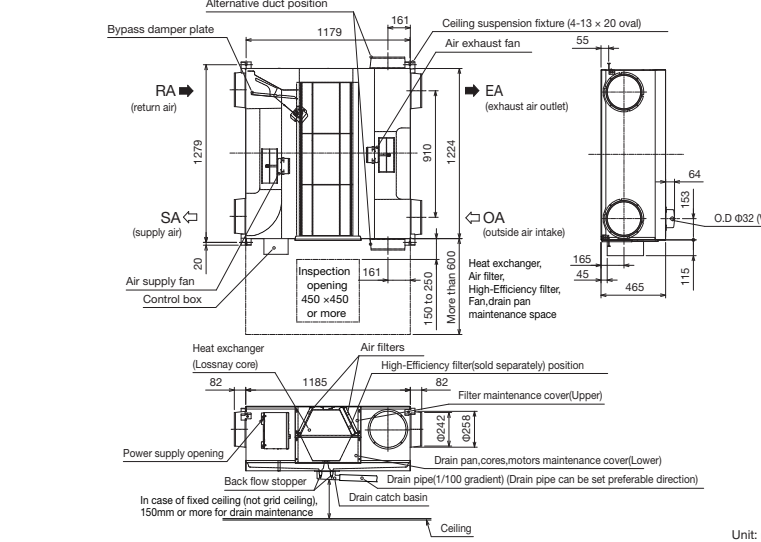

LGH-80RVS-E	63kg (77kg with maximum drain water)				
	220-240V/50Hz, 220V/60Hz				
Electrical power supply	Test condition				
Fan speed	100%	75%	50%	25%	
Input power [W]	325	175	85	32	
Airflow [m ³ /h]	800	600	400	200	
Airflow [L/s]	222	167	111	56	ISO 16494
Specific fan power [W/(L/s)]	1.46	1.05	0.77	0.58	Temp. exchange efficiency is winter condition
External static pressure [Pa]	170	96	43	11	
Temp. exchange efficiency [%]	82.0	84.0	86.0	90.0	A-weighted sound pressure level @1.5m off from the center of the unit in an anechoic chamber
Noise [dB]	36.0	30.0	25.0	18.0	Tracer gas method @100% airflow (prEN308)
Exhaust air transfer ratio [%]	5				
Insulation resistance	10MΩ or more				
Dielectric strength	AC 1000V 1 minute				
Maximum current [A]	3.70				
Inrush current [A]	6.1A @10ms, 3.6A@100ms				

Characteristic Curves

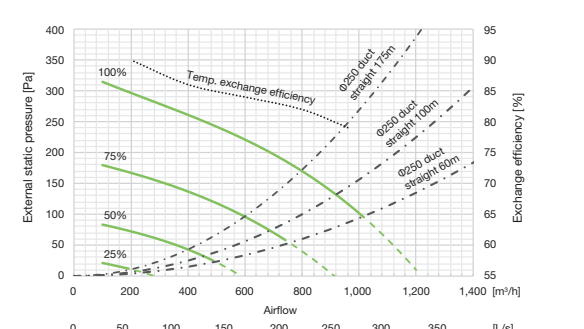

Dimensions

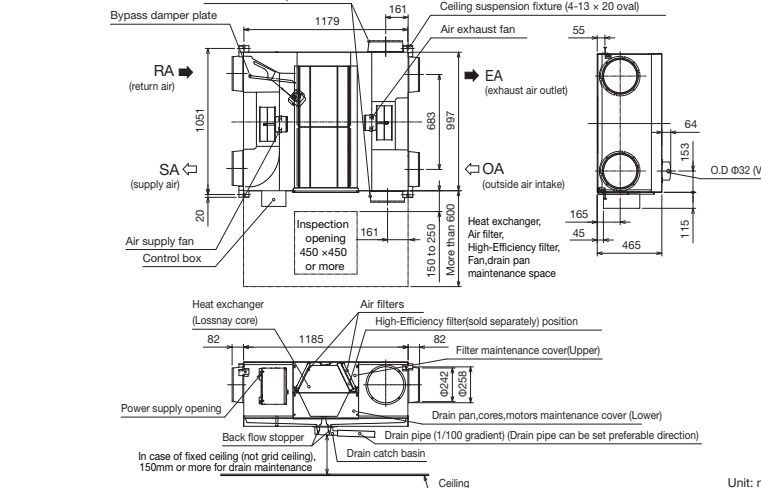

LGH-50RVS-E	55kg (67kg with maximum drain water)				
	220-240V/50Hz, 220V/60Hz				
Electrical power supply	Test condition				
Fan speed	100%	75%	50%	25%	
Input power [W]	190	110	60	25	
Airflow [m ³ /h]	500	375	250	125	
Airflow [L/s]	139	104	69	35	ISO 16494
Specific fan power [W/(L/s)]	1.37	1.06	0.86	0.72	Temp. exchange efficiency is winter condition
External static pressure [Pa]	150	84	38	9	
Temp. exchange efficiency [%]	87.0	89.0	91.0	93.0	A-weighted sound pressure level @1.5m off from the center of the unit in an anechoic chamber
Noise [dB]	33.0	27.0	22.0	18.0	Tracer gas method @100% airflow (prEN308)
Exhaust air transfer ratio [%]	5				
Insulation resistance	10MΩ or more				
Dielectric strength	AC 1000V 1 minute				
Maximum current [A]	2.20				
Inrush current [A]	6.1A @10ms, 3.6A@100ms				

Characteristic Curves

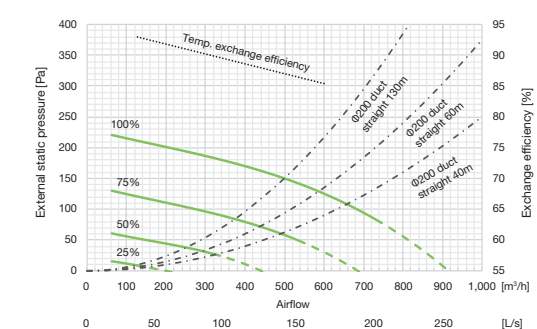

Dimensions

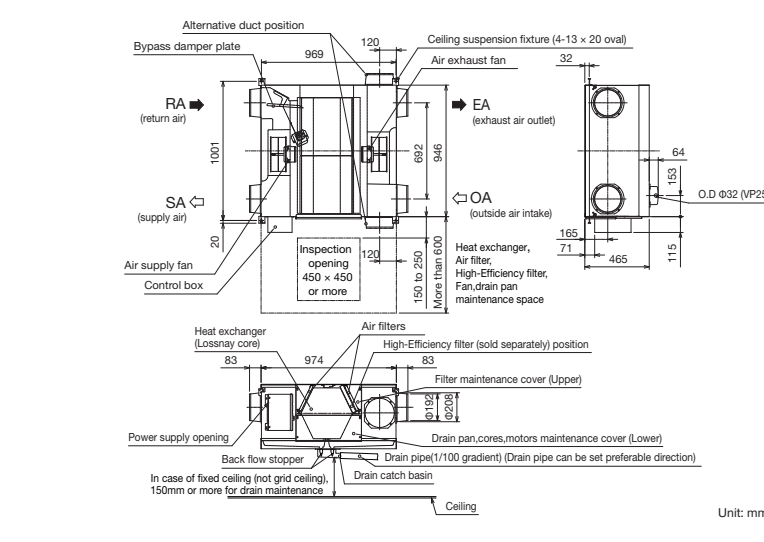

Controllers

PZ-62DR-E



PZ-43SMF-E



Function	PZ-62DR-E	PZ-43SMF-E
Fan speed selection	4 fan speeds and Auto (Auto is available when using a CO ₂ sensor)	2 of 4 fan speeds
Control with a CO ₂ sensor	Yes (Fan speed automatically changes from 25% to 100% depending on the CO ₂ concentration)	No
Ventilation mode selection	Energy recovery/Bypass/Auto	Energy recovery/Bypass/Auto
Night-purge	Yes	No
Function setting from remote controller	Yes	No
Bypass temp. free setting	Yes	No
Multi-stage airflow control	Yes (Both supply and exhaust fan speeds can be set separately from 25% to 100% in 5% pitches)	No
ON/OFF timer	Yes	Yes
Auto-off timer	Yes	No
Weekly timer	Yes	No
Fan speed timer	Yes	No
Operation restrictions (ON/OFF, ventilation mode, fan speed)	Yes	No
Operation restrictions (fan speed skip setting)	Yes	No
Screen contrast adjustment	Yes	No
Language selection	Yes	No (English only)
CO ₂ concentration indication	Yes (available when using a CO ₂ sensor)	No
Filter cleaning sign	Yes (maintenance interval can be changed)	Yes
Error indication	Yes (displays model name, serial number, contact information if they are input)	Yes
Error history	Yes	No
OA/RA/SA temp. display	Yes	No

*When using a CO₂ sensor. Upper and lower limits may be changed.